

EDT-S100

**PULEGGE
PULLEYS
SCHEIBEN**



Piazzalunga

SERCOIN
SUMINISTROS - TRANSMISIÓN

PULEGGE PULLEYS SCHEIBEN

Quando la variazione di velocità deve essere continua, precisa e, soprattutto, esente da manutenzione, le pulegge espansibili Piazzalunga della serie EDT o S100 offrono una risposta adeguata al problema. Tutto ciò grazie all'ampia gamma di potenze applicabili (0.37÷18.5 Kw) ed un rapporto di variazione 1:3, ma soprattutto grazie alle prestazioni consentite dai componenti: albero poligonale autolubrificante, semiflange in ghisa zincate o fosfatate, molle elicoidali in acciaio speciale al cromo-vanadio.

When speed variation must be continuous and precise, and above all free from maintenance, Piazzalunga EDT or S100 series expanding pulleys offer a suitable solution to the problem. This is possible thanks to the wide range of powers which can be applied (0.37 - 18.5 Kw) and 1:3 variation ratio, but above all thanks to component performance: selflubricating polygonal shaft, galvanized or phosphatized cast iron semiflanges, helical springs made of special chrome-vanadium steel.

Wenn die Geschwindigkeitsänderung stufenlos, präzise und vor allem wartungslos sein soll, so sind die spreizbaren Scheiben Piazzalunga der Serie EDT oder S100 eine geeignete Antwort des Problems. Dies dank der grossen Auswahl an anwendbaren Leistungen (0.37 - 18.5 Kw) und einem Variationsverhältnis von 1:3, doch vor allem dank den durch die Komponenten ermöglichten Betriebsleistungen: vieleckige selbstschmierende Welle, Halbflanschen aus verzinktem oder phosphatiertem Gusseisen, Schraubenfeder aus ChromVanadium-Stahl.

SERIE EDT

EDT SERIES - SERIE EDT

Rapporto di variazione 1:3

Variation ratio 1:3

Variationsverhältnis 1:3

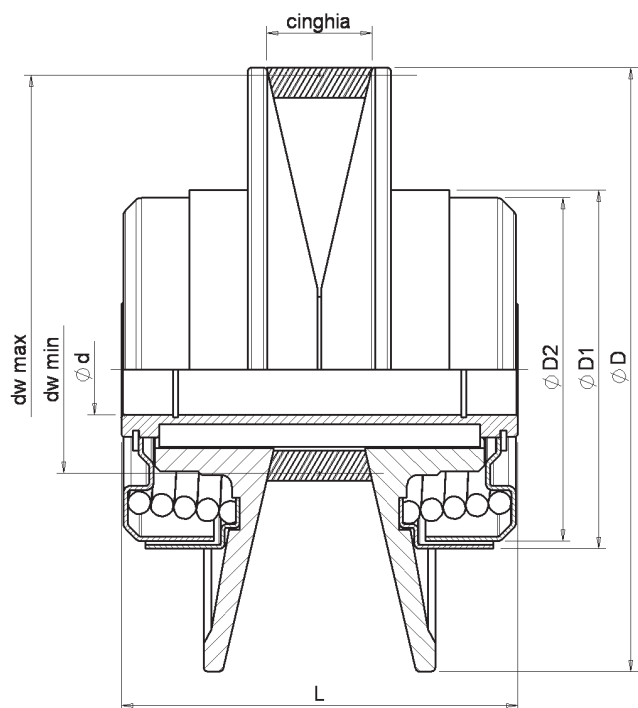

serie EDT



TABELLA DIMENSIONALE (mm) - DIMENSIONS TABLE - GRÖSSENTABELLE

GRANDEZZA SIZE GRÖSSE	130	160	185 ⁽³⁾	200	225	270 ⁽⁴⁾	300	330 ⁽³⁾	360
Potenza (Kw) - Power - Motorleistung ⁽¹⁾	0,75	1,5	2,2	2,2	3	4	7,5	15	18,5
Sezione cinghia - Belt - Reimen	22x8	28x8	37x10	37x10	47x13	47x13	55x15	65x20	70x20
ø d standard ⁽²⁾	14-19	19-24	24-28	24-28	28	28-38	38	38-42	42-48
ø d max ⁽²⁾	24	25	30	30	30	42	42	42	50
ø D	130	160	185	195	225	270	300	330	360
ø D ₁	85	95	95	95	106	133	201	201	201
ø D ₂	77	91	91	91	101	129	196	196	196
dw min	51	56	68	68	72,5	82,5	90,5	96	110
dw max	126	156	180	190	219	263,5	292,5	320	350
L	92	105	125	125	140	150	180	220	220
Peso (kg) - Weight - Gewicht	2	3,5	5	5	7	14	18	25,5	27

(1) MOTORI A 4 POLI 1400/1' - 4 POLES MOTORS 1400/1' - MOTOREN BEI 4 POLIG 1400/1'

(2) FORI - BORES - BOHRUNG: ISO H7

(3) FORNIBILI SOLO SU RICHIESTA - ONLY ON DEMAND - NUR AUF ANFRAGE
ESECUCIONI SPECIALI A RICHIESTA - SPECIAL VERSIONS ON REQUEST - SPEZIALAUSFÜHRUNGEN AUF ANFRAGE

(4) FORNIBILE ESCLUSIVAMENTE IN ESECUZIONE EDS CON MOLLE A DIAFRAMMA - AVAILABLE ONLY WITH DIAPHRAGM SPRINGS -
NUR MIT MEMBRANFEDERN VERFÜGBAR

CAVE - KEYWAYS - NUT: UNI 6604/69 - DIN 6885/1-3

DATI NON IMPEGNATIVI - NOT BINDING DATA - UNVERBINDLICHE DATEN

SERIE 100

100 SERIES - SERIE 100

Rapporto di variazione 1:3

Variation ratio 1:3

Variationsverhältnis 1:3

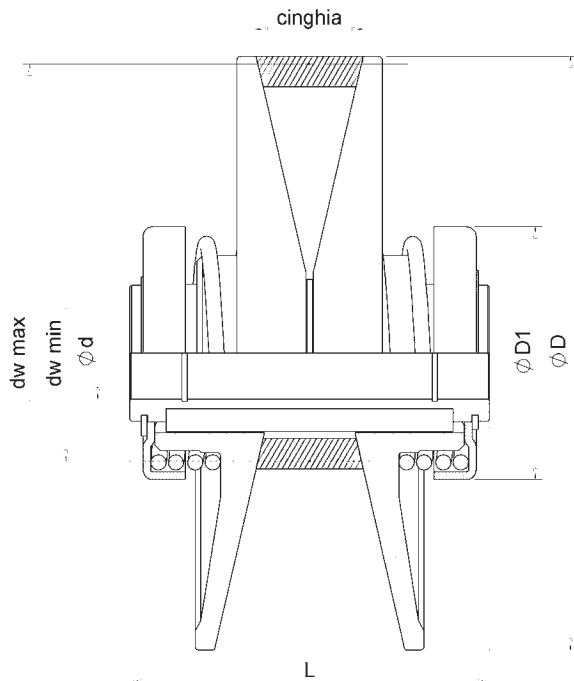

serie 100



TABELLA DIMENSIONALE (mm) - DIMENSIONS TABLE - GRÖSSENTABELLE

GRANDEZZA SIZE GRÖSSE	95	110	120	155	180	220
Potenza (Kw) - Power - Motorleistung ⁽¹⁾	0,37	0,55	0,75	1,5	3	4
Sezione cinghia - Belt - Reimen	13x6	17x5	22x8	28x8	28x8	47x13
ø d standard ⁽²⁾	14	14-19	14-19	19-24	24-28	37x10
ø d max ⁽²⁾	20	20	22	25	30	28
ø D	95	110	120	155	180	30
ø D ₁	58	58	58	66	85	220
dw min	40	38,5	48	50	58	85
dw max	92	107,5	116	151	176	61
L	65	72	72	94	110	125
Peso (kg) - Weight - Gewicht	1	1,4	1,6	2,5	4	5

(1) **MOTORI A 4 POLI 1400/1' - 4 POLES MOTORS 1400/1' - MOTOREN BEI 4 POLIG 1400/1'**

(2) **FORI - BORES - BOHRUNG: ISO H7**

CAVE - KEYWAYS - NUT: UNI 6604/69 - DIN 6885/1-3

DATI NON IMPEGNATIVI - NOT BINDING DATA - UNVERBINDLICHE DATEN

PULEGGE CONDOTTE

DRIVEN PULLEYS - ABTRIEBSRIEMENSCHLEIBEN

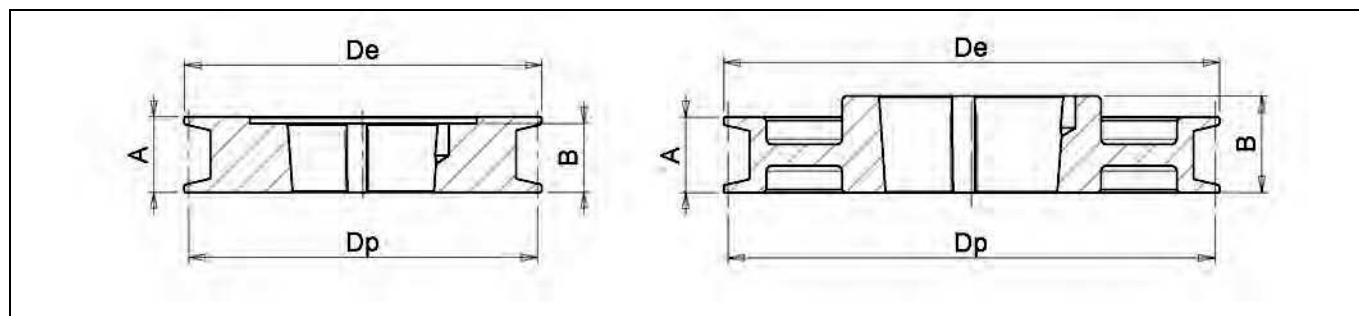

CINGHIA	GRAND	TAPER	De	Dp	A	B	Peso [kg] Weight [kg]
22x8	100	1610	99,6	95,6	28,0	25,0	0,60
	115		116,6	112,6	28,0	25,0	1,04
	130		129,6	125,6	28,0	25,0	1,44
	165	2012	164,6	160,6	28,0	32,0	2,89
	205		204,6	180,6	28,0	32,0	3,13
28x8	130	1610	130,5	126,5	35,0	25,0	1,65
	165	1615	165,5	161,5	35,0	32,0	3,33
	230	2517	229,5	225,5	35,0	45,0	4,91
	320		320,5	316,5	35,0	45,0	8,21
	455		455,5	451,5	35,0	45,0	8,18
37x10	185	2517	187,0	181,0	44,0	45,0	4,78
	230		231,0	225,0	44,0	45,0	5,44
	255		257,0	251,0	44,0	45,0	6,12
	320		322,0	316,0	44,0	45,0	8,66
47x12	165	2517	165,5	159,0	50,0	45,0	3,50
	230		229,5	223,0	50,0	45,0	4,92
	263		255,5	249,0	50,0	45,0	5,75
	285		285,5	279,0	50,0	45,0	6,80
	320	3020	320,5	314,0	50,0	51,0	12,55
	405		405,5	399,0	50,0	51,0	9,00
55x15	320	3020	322,0	314,5	63,0	51,0	9,45
	360	3535	362,0	354,5	63,0	51,0	11,22
	405		407,0	399,5	63,0	89,0	17,06
	460	457,0	449,5	63,0	89,0	18,91	
65x20	325	3535	325,0	314,6	80,0	89,0	16,56
	345		345,0	334,6	80,0	89,0	16,95
	365		365,0	354,6	80,0	89,0	17,70
	410		410,0	399,6	80,0	89,0	21,22
	460		460,0	449,6	80,0	89,0	23,08
70x20	365	3535	365,0	355,0	85,0	89,0	17,93
	410		410,0	400,0	85,0	89,0	21,58
	460		460,0	450,0	85,0	89,0	23,48
	510		510,0	500,0	85,0	89,0	26,09

Per determinare i dati necessari al dimensionamento di una trasmissione ad interasse fisso risulterà comodo utilizzare le formule sottoelencate.

1. Determinazione dello sviluppo interno della cinghia

Considerando che i d_w riportati sul catalogo per convenzione sono calcolati come segue:

- 1.1 Determinare "di min" e "Di max" delle pulegge.
- 1.2 Calcolare lo sviluppo interno teorico della cinghia;

To determine the data required to size a transmission with fixed axle base, it is convenient to use the formulas given below.

1. Determination of the internal belt development

Considering that the d_w indicated in the catalogue are normally calculated as follows:

$$h_w = 0,25h$$



- 1.1 Determine the "min. di" and "max. Di" of the pulleys.
- 1.2 Calculate the theoretical internal development of the belt.

Zur Bestimmung der zur Bemessung eines Getriebes mit festem Achsenabstand erforderlichen Daten ist es zweckmäßig, unten aufgeführte Formeln anzuwenden.

1. Bestimmung der Innenabwicklung des Riemens

Unter Berücksichtigung der Tatsache, dass die im Katalog angegebenen d_w laut Konvention wie folgt berechnet werden:

- 1.1 "di min." und "Di max." der Riemenscheiben bestimmen.
- 1.2 Die theoretische Innenabwicklung des Riemen berechnen:

$$L_i = 2A + \pi/2 (d_i + D_i) + \frac{(d_i - D_i)^2}{4A}$$

- dove: A = interasse del variatore.
 d_i = diametro interno minimo contatto cinghia puleggia motrice.
 D_i = diametro interno massimo contatto cinghia puleggia condotta.
 L_i = sviluppo interno cinghia teorico.

- where: A = variator axle base.
 d_i = minimum internal diameter of belt driving pulley.
 D_i = maximum internal diameter of belt driven pulley.
 L_i = theoretical internal belt development.

- wo: A = Achsenabstand des Variators.
 d_i = minimaler Innendurchmesser Kontakt Riemen Antriebsriemenscheibe.
 D_i = maximaler Innendurchmesser Kontakt Riemen angetriebene Riemenscheibe.
 L_i = theoretische Innenabwicklung Riemen.

2. Determinazione della corsa di regolazione della slitta portamotore

Nel caso di trasmissioni con pulegge a doppia espansione (EDS e S100) e condotte fisse si determinerà la corsa della slitta procedendo come segue:

2. Determination of the adjustment stroke of the motor support slide

For transmission with two-way pulley expansion (EDS and S100) and fixed driven pulleys, the stroke of the slide is determined as follows:

2. Bestimmung der Einstellhub des Motorschlittens

Im Falle von Riemenscheibenantrieben mit doppelter Spreizung (EDS und S100) und fester angetriebener Riemenscheibe, wird die Hub des Schlittens wie folgt bestimmt:

$$A_{max} = 0,5 \left[L_i - \pi/2 (d_1 + D_2) - \frac{(d_1 - D_2)^2}{L_i} \right] \quad A_{min} = 0,5 \left[L_i - \pi/2 (D_1 + D_2) - \frac{(D_1 - D_2)^2}{L_i} \right]$$

$$A_{max} - A_{min} = \text{corsa/stroke/Hub}$$

- dove: d_1 = diametro interno minima cinghia puleggia motrice.
 D_1 = diametro interno massimo contatto cinghia puleggia motrice.
 D_2 = diametro interno contatto cinghia puleggia condotta.
 L_i = sviluppo interno cinghia teorico.

- where: d_1 = minimum internal diameter of belt driving pulley.
 D_1 = maximum internal diameter of belt driving pulley.
 D_2 = internal diameter of belt driven pulley contact.
 L_i = theoretical internal belt development.

- wo: d_1 = minimaler Innendurchmesser Kontakt Riemen Antriebsriemenscheibe.
 D_1 = maximaler Innendurchmesser Kontakt Riemen Antriebsriemenscheibe.
 D_2 = Innendurchmesser Kontakt Riemen angetriebene Riemenscheibe.
 L_i = Innenabwicklung Riemen.

Per ulteriori chiarimenti o per esecuzioni speciali contattate il nostro ufficio tecnico.

For further clarification or special versions, please contact our technical office.

Für weitere Erklärungen oder für Spezialausführungen wollen Sie sich bitte an unser technisches Büro wenden.